

MANUAL TORQUE WRENCHES



11 SIZES AVAILABLE

FEATURES

- Industrial Application
- Tolerance of torque $\pm 3\%$
- Easy torque-adjusting design
- Quick release design
- Applied to both clockwise and counter clockwise directions
- Quality meets DIN ISO 6789 & ASME B107.300-2010
- Supplied with Certificate of Calibration
- Supplied with robust carry case
- Dual scale (Nm/FT-LB)

SPECIFICATIONS

Model No.	Square Drive	Teeth	Torque Range	Graduation (Nm)	Weight (kg)	OAL
TQ-20	3/8"	24T	4 – 20Nm / 39.8 – 172.6 IN-LB	0.1	0.65	329mm
TQ-60	3/8"	32T	10 – 60Nm / 9.2 – 42.4 FT-LB	0.5	0.76	344mm
TQ-100	1/2"	32T	20 – 100Nm / 16.6 – 71.9 FT-LB	0.5	1.31	436mm
TQ-200	1/2"	32T	40 – 200Nm / 33.2 – 143.8 FT-LB	1.0	1.58	512mm
TQ-340	1/2"	32T	60 – 340Nm / 51.6 – 243.4 FT-LB	2.0	1.8	614mm
TQ-400	3/4"	32T	80 – 400Nm / 66.4 – 287.8 FT-LB	2.0	1.8	614mm
TQ-600	3/4"	24T	100 – 600Nm / 92 – 424 FT-LB	5.0	5.03	1050mm
TQ-800	3/4"	24T	150 – 800Nm / 129 – 572 FT-LB	5.0	6.11	1240mm
TQ-1000	3/4"	24T	200 – 1000Nm / 166 – 719 FT-LB	5.0	6.11	1240mm
TQ-1500	1"	24T	300 – 1500Nm / 258 – 1070 FT-LB	10.0	10.6	1850mm
TQ-2500	1"	36T	500 – 2500Nm / 443 – 1771 FT-LB	20.0	19.6	2920mm

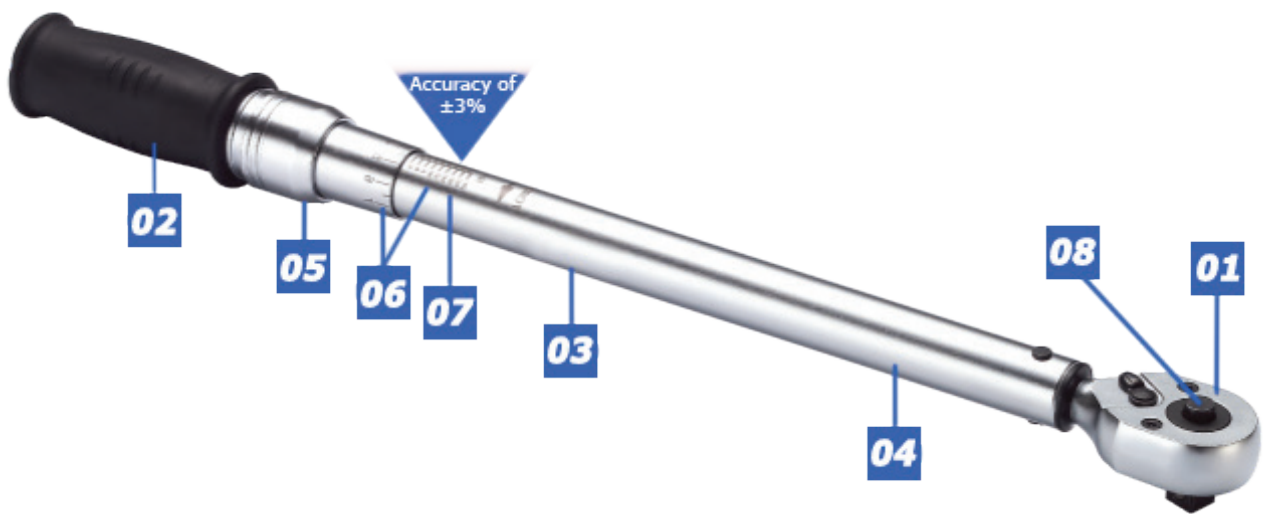

01 Ratchet head:

Robust ratchet mechanism for Clockwise and Counter-Clockwise applications with quick-release design, enabling the fast changing of the socket. Ratchet head repair kit available separately.

02 TPR handle:

The TPR (thermoplastic rubber) handle provides non-slip technology and comfort features. REACH - SVHC Declaration of Conformity.

03 Serial number:

Each wrench has its serial number engraved for traceability.

04 Reliable mechanism:

The chrome steel tube is robust and reliable, making it ideal for industrial use. An audible and palpable signal indicates when the desired torque value is achieved.

05 Lock ring:

Pressing down on the lock-ring provides easy torque adjustment with minimal effort required. The lock ring locks automatically to avoid any changes to the set torque value.

06 Scales:

Easy to read laser scales provide flexibility for different market needs.

07 Micrometer scales:

Precise adjustment is enabled by the micrometer laser scales on the handle. The adjustment is measured in integral values enabling the reading to be made with round figures.

08 Spring loaded push pin:

Spring loaded push pin to remove hex socket.